

Owners manual

WCJ, MCJ, STJ, LMJ Öhlins shock absorbers

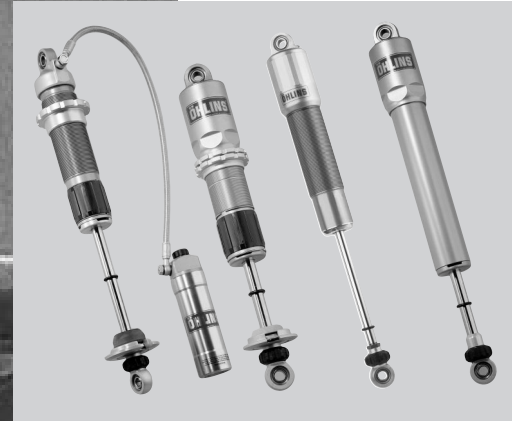

Including:

Key features

Design

How the shock absorber works

Technical info

Öhlins shock absorbers

WCJ 58000

WCJ 68000

MCJ 08200

MCJ 08400

MCJ 08600

MCJ 08800

STJ 15400/15450

STJ 17500/17550

STJ 19600/19650

STJ 21700/21750

STJ 23800/23850

STJ 25900/25950

LMJ 55000

LMJ 58000

LMJ 68000

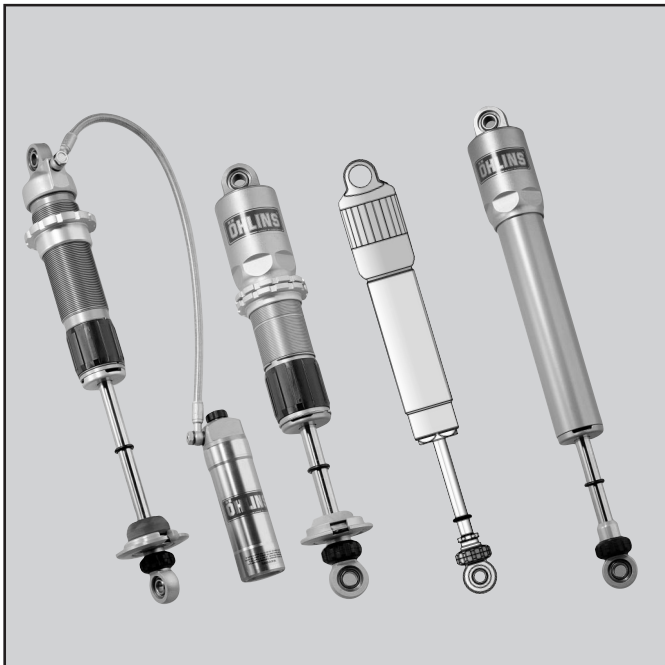

Contents

Safety	2
Key features	3
Design	5
How the shock absorbers work	6
Optional parts	8
Service tools	8

Safety signals

Important information concerning safety is distinguished in this manual by the following notations



*The Safety alert symbol means:
Caution! Your safety is involved.*

⚠ WARNING!

*Failure to follow warning instructions could result in **severe or fatal injury** to anyone working with, inspecting or using the suspension, or to bystanders.*

CAUTION!

Caution indicates that special precautions must be taken to avoid damage to the suspension.

NOTE!

This indicates information that is of importance with regard to procedures

Before installation

⚠ WARNING!

Installing a shock absorber, that is not approved by the vehicle manufacturer, may affect the stability of your vehicle. Öhlins Racing AB cannot be held responsible for any personal injury or damage whatsoever that may occur after fitting the shock absorber. Contact an Öhlins dealer or other qualified person for advice.

Öhlins Racing AB can not be held responsible for any damage whatsoever to shock absorber or vehicle, or injury to persons, if the instructions for fitting and maintenance are not followed exactly. Similarly, the warranty will become null and void if the instructions are not adhered to.

⚠ WARNING!

Please study and make certain that you fully understand all the mounting instructions and the owner's manuals before handling this shock absorber kit. If you have any questions regarding proper installation procedures, contact an Öhlins dealer or other qualified person.

⚠ WARNING!

The vehicle service manual must be referred to when installing the Öhlins shock absorber.

NOTE!

Öhlins products are subject to continual improvement and development. Consequently, although these instructions include the most up-to-date information available at the time of printing, there may be minor differences between your suspension and this manual. Please consult your Öhlins dealer if you have any questions with regard to the contents of the manual.

Key features

Öhlins WCJ series

- Designed for Winston Cup, Busch GN and ARCA
- Lightweight aluminum body
- Large reservoir for better cooling
- Double acting damper adjuster
- Quick response for best handling
- Optimum consistency on long runs
- Easy to dial-in, reshim, rebuild and service
- Professional technical support
- Base valve
- Large diameter floating piston

Technical information

Shock absorber model	Total stroke in mm	Total stroke in inches	Total length in mm	Total length in inches
WCJ 58000	171 mm	6.7"	382 mm	22"

Technical information

Adjustable models

WCJ 58000	171 mm	6.7"
	560 mm	22.0"
WCJ 68000	191 mm	7.5"
	600 mm	23.6"

$\varnothing A = 64 \text{ mm}$ (2.5")
 $\varnothing B = 51 \text{ mm}$ (2.0")

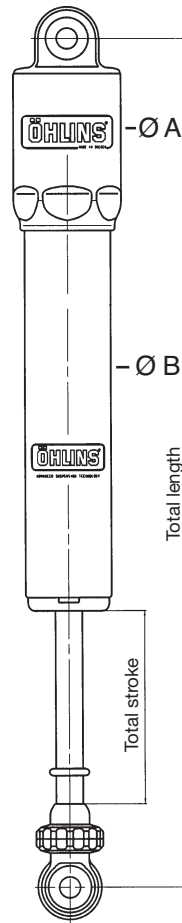

Öhlins MCJ series

- Designed for Late Models, Modifieds, Sprint and many other cars
- Lightweight threaded aluminum body
- Large reservoir for better cooling
- Double acting damper adjuster
- Quick response for best handling
- Optimum consistency on long runs
- Easy to dial-in, reshim, rebuild and service
- Professional technical support
- Base valve
- Large diameter floating piston
- Includes coil-over kit

Adjustable models

MCJ 08200	103 mm	4.0"
	417 mm	16.4"
MCJ 08400	139 mm	5.5"
	495 mm	19.5"
MCJ 08600	168 mm	6.6"
	557 mm	21.9"
MCJ 08800	223 mm	8.8"
	667 mm	26.2"

$\varnothing A = 64 \text{ mm}$ (2.5")
 $\varnothing B = 55 \text{ mm}$ (2.2")

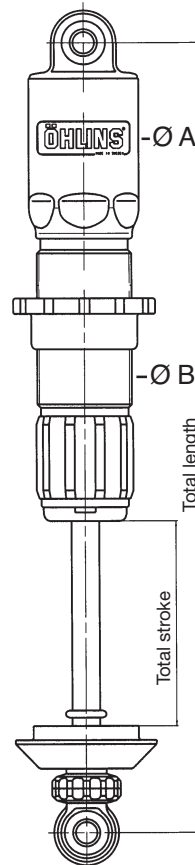

Öhlins STJ series

- Designed for Late Models, Modifieds, Sprints and many other cars
- Lightweight threaded aluminum body
- Large reservoir for better cooling
- Available as adjustable or non-adjustable
- Quick response for best handling
- Optimum consistency on long runs
- Optional coil-over kit
- Owner rebuildable
- Easy to dial-in, reshim, rebuild and service
- Professional technical support

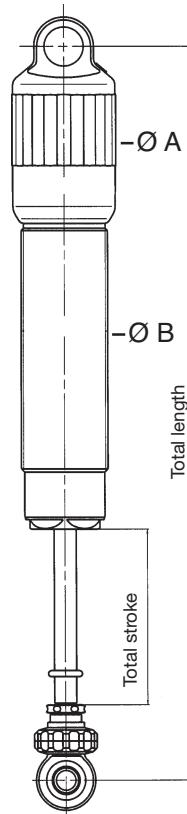

Technical information

Adjustable models

STJ 15400	103 mm	4.0"
	382 mm	15.0"
STJ 17500	128 mm	5.0"
	436 mm	17.2"
STJ 19600	153 mm	6.0"
	490 mm	19.3"
STJ 21700	178 mm	7.0"
	544 mm	21.4"
STJ 23800	203 mm	8.0"
	598 mm	23.5"
STJ 25900	228 mm	9.0"
	652 mm	25.6"

Non-adjustable models

Non-adjustable with the same stroke but 0.2" shorter overall length.

Non-adjustable:

STJ 15450
STJ 17550
STJ 19650
STJ 21750
STJ 23850
STJ 25950

Ø A = 64 mm (2.5")
Ø B = 51 mm (2.0")

Öhlins LMJ series

The Öhlins LMJ stock car shock absorbers are based on the race proven Öhlins type 46HRC, a shock absorber with a large reservoir, mounted by a hose (H) features separate rebound (R) and compression damping (C) adjusters.

The large shock absorber reservoir, connected to the shock absorber body by a hose contributes to the improved cooling. The reservoir contains the floating piston and the gas that pressurizes the damping fluid.

- Designed for classes like Late Model, Dirt Modified and Sprintcar
- Lightweight aluminum body
- Large reservoir for better cooling
- 2-way adjustable damping
- Quick response for best handling
- Optimum consistency on long runs
- Easy to dial-in, reshim, rebuild and service
- Professional technical support

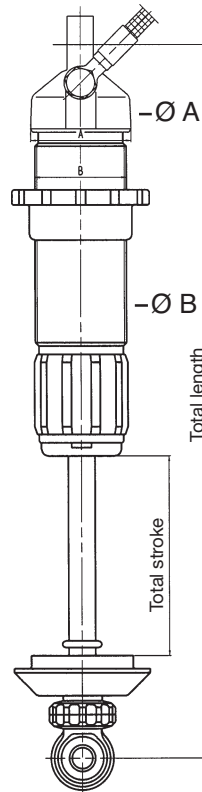

Adjustable models

LMJ 55000	139 mm	5.5"
	434 mm	17.0"
LMJ 58000	179 mm	7.0"
	502.5 mm	19.8"
LMJ 68000	229 mm	9.0"
	591.5 mm	23.3"

Ø A = 64 mm (2.5")
Ø B = 51 mm (2.0")

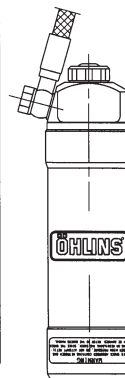

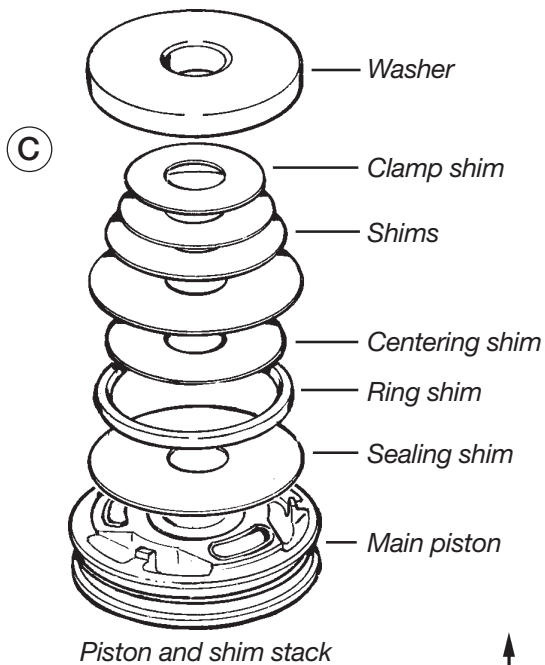
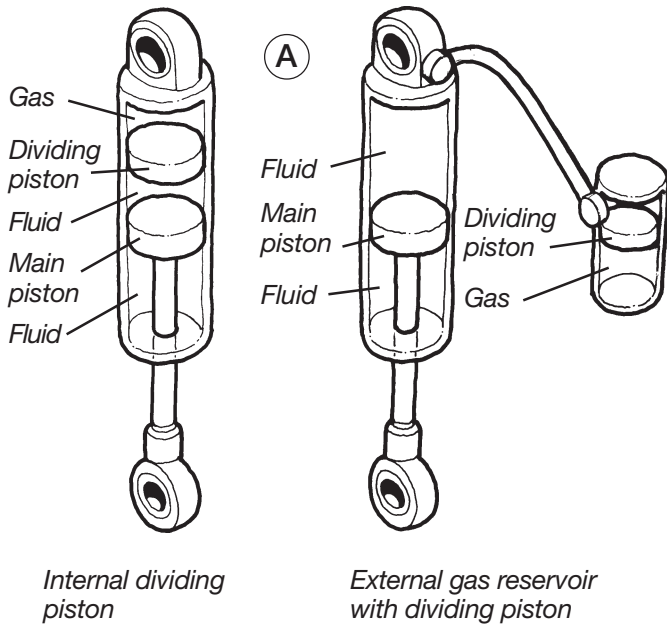

Design

The Öhlins WCJ, MCJ, STJ and LMJ are all based on Öhlins successful application of the "de Carbon" concept that has won more than 60 World Championship titles.

The de Carbon concept; the damping fluid placed under pressure by gas and separated from the gas by a floating piston, has several advantages (fig. A). It prevents the risk of cavitation, that can wear out internal components and cause inconsistent damping, and it eliminates aeration of the damping fluid, which also causes inconsistent damping. It improves the cooling, because the fluid is in direct contact with the outer tubing. It gives more consistent damping, regardless of the shock absorber's working temperature, and it makes the shock absorber last longer.

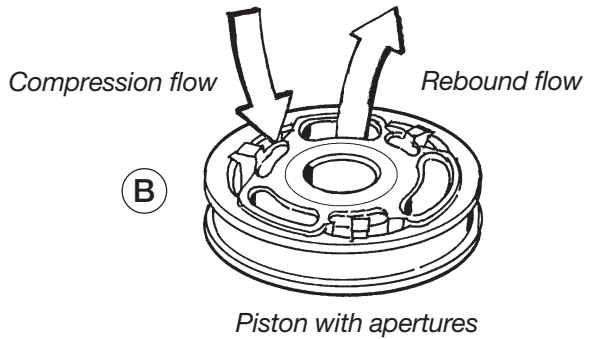

The main piston (fig. B), is specially developed for oval track racing. Thanks to the shape of the apertures in the piston the damping force builds up rapidly. The result is excellent short stroke/high force performance.

The internal pressure is balanced to cope with temperature build up and to prevent any chance of cavitation, yet reducing the fluid compressibility and the friction from the pistons and the shaft seal.

The new Öhlins shock absorbers are built to perform and endure. They are easy to set up and to sort out. Thanks to the design of the main body they are also easy to maintain and to rebuild.

All Öhlins shock absorbers are built with a desire to win and with precision that ends up in quality, a quality you can see and feel.

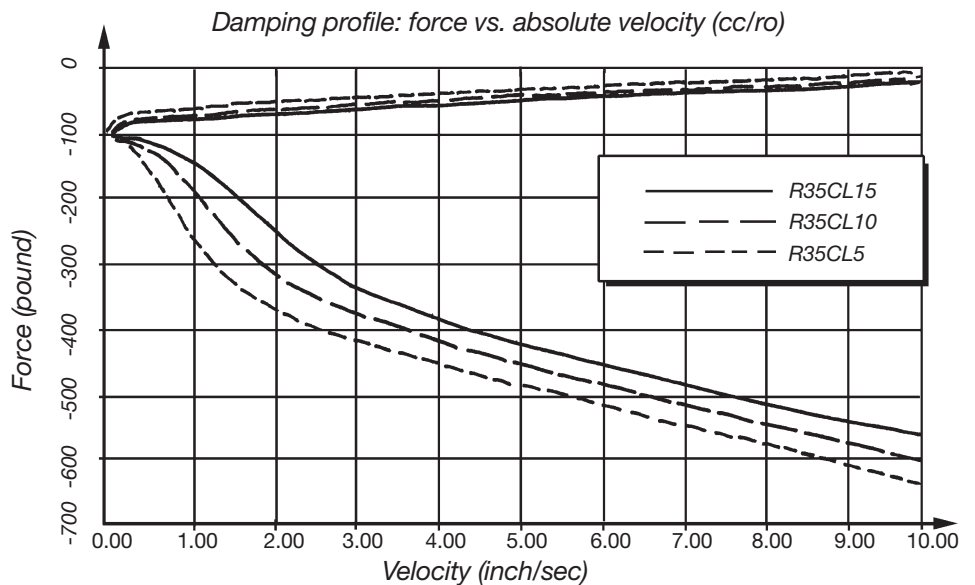

How the shock absorbers work

Compression damping

During a compression stroke, path 1 (Fig 1) is closed, the fluid can flow through paths 2 and 3. The damping forces at a certain compression speed are determined by the flow restrictions in these paths.

The flow restriction through path 2 is determined by how much the fluid pressure can open the compression shims which are closed shut whenever the pressure is too low or the shock is not moving in a compression mode.

The shim stack's resistance to opening is decided by the quantity, thickness and diameters of the shims, and are carefully chosen to make each shock give optimum results.

Path 3 is the main bleed valve, the larger the orifice the less fluid flows through path 2 making the main valve compression forces lower.

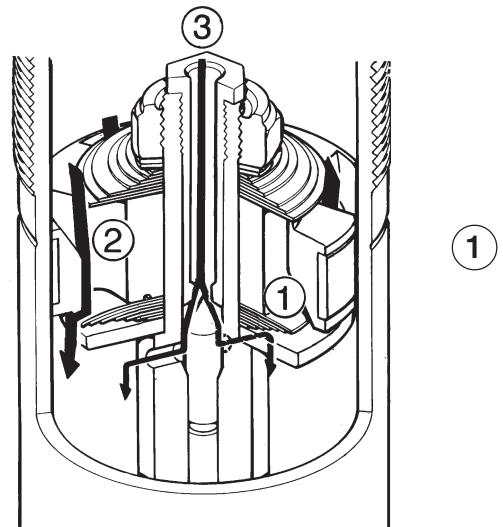

Rebound damping

During a rebound stroke path 2 (Fig 2) is closed and fluid can pass through paths 1 and 3. Damping forces are determined by the flow restriction in these paths.

The flow restriction through path 1 is determined by how much the fluid pressure can open the rebound shims which are closed shut whenever the pressure is too low or the shock is not moving in a rebound mode. These shims are also carefully chosen to give the best set-up.

Path 3 is the main bleed valve, the larger the orifice the less fluid flows through path 1 making the main valve rebound forces lower. On adjustable models the size of the orifice can be changed with an adjuster knob.

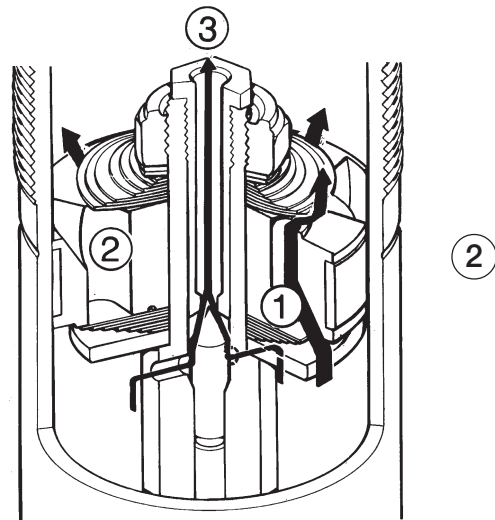

External adjustment

The external adjuster knob, easy to reach on the piston shaft just above the eyelet (Fig 3) is connected to the main bleed valve via an aluminum rod that runs inside the piston shaft. When the temperature in the shock increases, the rod expands, keeping the flow through the valve exactly the same at all working temperatures.

The adjuster moves the needle in the main bleed valve, which determines the orifice size of path 3 (Fig 1 and 3). When the adjuster knob is turned all the way clockwise to the closed position, the shock is the most restrictive to rebound movement, rebounding at its slowest.

This position is the starting point for counting out the clicks (in a counter clockwise direction) to the recommended adjuster position, normally 8-25 clicks.

This adjustment has the greatest effect on the rebound damping, but it also has an effect on the compression damping at a ratio of approximately; 10% compression and 90% rebound.

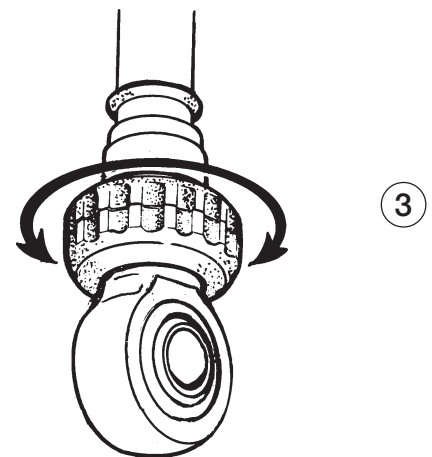

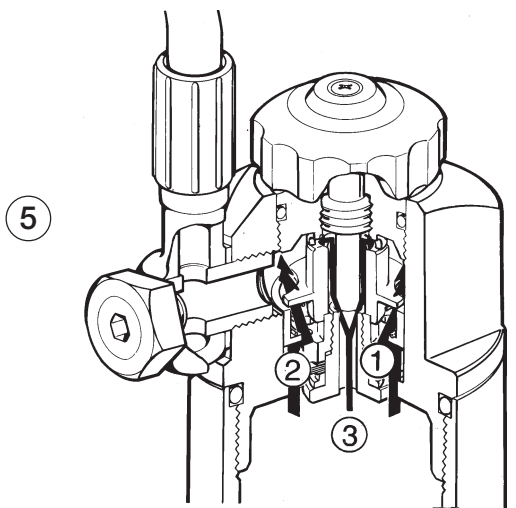
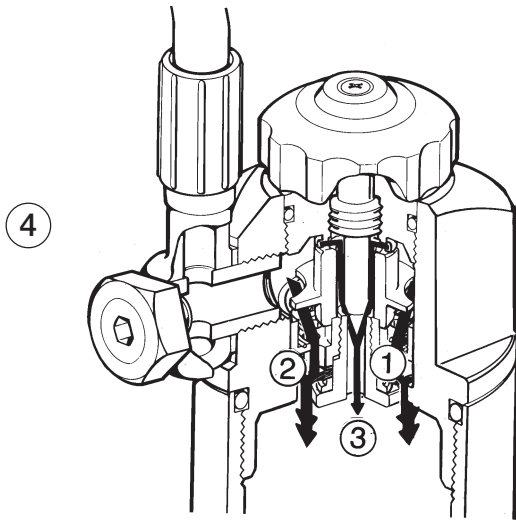

External compression adjuster (LMJ only)

With the second adjustable bleed valve on top of the reservoir, you can adjust the compression damping.

The valve restricts the oil flow to the reservoir but not from it, thereby only influencing the compression damping (fig. 4).

The fluid displaced by the piston shaft is forced through the independent compression damping adjuster out into the external reservoir (fig. 4, flow 3).

The floating piston in the reservoir is forced to move, compressing the gas behind it further.

When the shock absorber extends, the pressure behind the floating piston will force the fluid through a one-way valve, and back into the shock absorber body (fig. 5, flow 1 and 2).

Also, fluid displaced by the piston shaft can not be forced fast enough through just the valve in the reservoir. The pressure increases and a shim stack parallel to the valve opens (fig. 4, flow 1 and 2).

The floating piston is forced to move, compressing the gas.

When the shock absorber extends, the floating piston will force the fluid through the one-way valve and back into the shock absorber body (fig. 5, flow 1 and 2).

Making adjustments

Suspension settings are dependent on your car's weight, your driving style, track conditions, etc. If you are not happy with our recommended settings, here are a few guidelines and ground rules on how to make adjustments.

To make improvements, it is important to understand that the function of the shock absorbers and through testing learn how they affect the handling of you car.

When making adjustments, always start with the Öhlins recommended settings. Keep notes, make adjustments one at a time... and in small steps.

The adjusters should normally not be adjusted in steps of more than 2 clicks at a time and not outside the usable click range. Most settings work best with 5-25 clicks.

When you think you have made an improvement, go back to what you started with and double check to be sure. Pay attention to changes in conditions like tires, temperatures, etc.

In general, compression damping changes should be used to influence the car's stability and response, while rebound damping changes should be used to influence comfort and traction.

When you need more damping force, you should mainly try to increase compression damping and use as little rebound damping as possible.

This usually means that you gain comfort and handling performance.

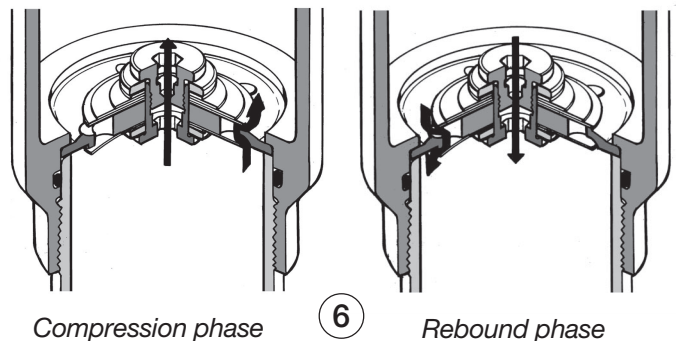

Base plate (WCJ and MCJ only)

The Öhlins WCJ and MCJ shock absorbers features a base plate, which allows the damper to work smoother and safer (fig.6).

This base plate eliminates the cavitation risk, without the need of increased gas pressure. It consists of a fixed dividing wall with apertures and with shims on both sides. In the center there is a jet that is available in different sizes.

The stiffer the compression valving on the main piston, the more restrictive the hole in the base plate jet.

The fluid that flows through the base plate is the volume of the shaft displacement, which also moves the floating piston.

The shims on the compression side eliminate the risk of cavitation, and the shims on the rebound side works as a check valve.

Optional parts

Double digressive piston:

This piston can produce high forces at low speed while maintaining a level slope at high speeds.

High frequency piston:

Excellent for traction and grip on flat tracks.

One way shaft jets:

Allows the compression bleed valve to be smaller than the rebound bleed valve.

Parallel compression valve:

Allows the rebound bleed valve to be smaller than the compression bleed valve and makes it possible to produce double-knee curves (not yet available for STJ).

External adjuster kit for STJ:

Complete kit to convert a non-adjustable shock to an adjustable model.

Coil over kit for STJ:

Contains all the parts needed to convert the shock into a coil over shock.

Service tools



Öhlins USA, Inc.

703-C Old Spartanburg Road, Hendersonville, NC 28792

Tel: 828-692-4525 Fax: 828-692-0595

www.ohlins.com

Öhlins Authorized USA Dealers

AMF Motorsports, Inc.

West Chesterfield, NH

Tel: 603-256-6800 Fax: 603-256-8142

Brooks Racing Engines

Colorado Springs, CO

Tel: 719-632-5496 Fax: 719-632-0183

BSR Products, Inc.

Charlotte, NC

Tel: 704-795-0901 Fax: 704-795-7403

Harrison Auto Dynamics

Phoenix, AZ

Tel: 602-254-0024 Fax: 602-254-5655

Howe Racing Enterprises

Beaverton, MI

Tel: 517-435-7080 Fax: 517-435-3331

Motorsports Spares International, Inc.

Indianapolis, IN

Tel: 317-241-7500 Fax: 317-241-0823

Naake Motorsports

Roseville, CA

Tel: 916-771-0109 Fax: 916-771-5201

John Page Racing

Rock Hill, SC

Tel: 803-366-7535 Fax: 803-366-7599

The Shock Shop

Portland, OR

Tel: 503-621-0621 Fax: 503-621-0622

SHY Racing Suspensions

Murfreesboro, TN

Tel: 615-893-0150 Fax: 615-896-8430

Manufactured by

Öhlins Racing AB, Box 722, S-194 27 Upplands Väsby, Sweden